

PRODUCT MANUAL



TTC6050 CNC Router



Language: English



Note: The picture is for reference only, the actual product may vary.

To our customers

Dear Customer:

To ensure that you can assemble and use it smoothly, we have prepared this assembly and use guide instruction manual. Please read the following content carefully and operate according to the instructions to ensure the safety and convenience when using.

If you encounter any problems during use, you can scan the QR code, company address and USB flash drive information to obtain the relevant instructions and videos. When the machine breaks down, please refer to the name of the corresponding part in the machine, and contact us with the problem and machine condition according to the after-sale e-mail provided on this page.

After-sales Email: service@twotrees3d.com Wikipedia: wiki.twotrees3d.com

Inquiry Email: info@twotrees3d.com



Web page for information

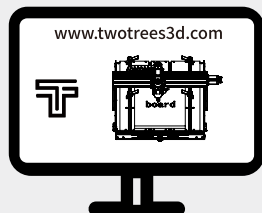

Login to www.twotrees3d.com,
find the corresponding model information
and equipment use information tutorials.

TF card information



Find the USB drive in the toolkit



To our customers

Safety Warning:

1. When using the machine for the first time, please make sure that the machine installation is firm.
2. When danger occurs, press the emergency stop button quickly.
3. Wear safety glasses when operating the machine.
4. Please use a brush to remove debris, do not blow with your mouth.
5. Be careful with sharpness when using Milling tools or sanding workpieces.
6. Install Milling tools, make sure it is solid.
7. When loading and unloading, setting knife, measuring and cleaning, please make sure that the machine must be stopped before operation.
8. Do not wear cotton gloves during operation.
9. Do not place measuring tools or other sundries within the scope of the workbench.
10. Clamp the workpiece firmly, do not start engraving when it cannot be loosened or not clamped.
11. This engraving machine needs to be used in an indoor setting.

TABLE OF CONTENTS

1.Unboxing Operation	01
2. Part list	06
3. Machine Assembly	10
3.1. Base Assembly	10
3.2. X-axis Assembly	18
3.3.Machine Main Assembly	19
3.4.Z-axis Assembly	23
3.5.Machine wiring	26
4. Operating Instructions	28
5. Common Questions and Answers	35
6.Machine Specifications	39

1、Unboxing Operation

Remove the tool kit, screw kit, work pressure plate, left component, right component, density board support, Y-axis support components in sequence.

Remove the first layer of pearl cotton.

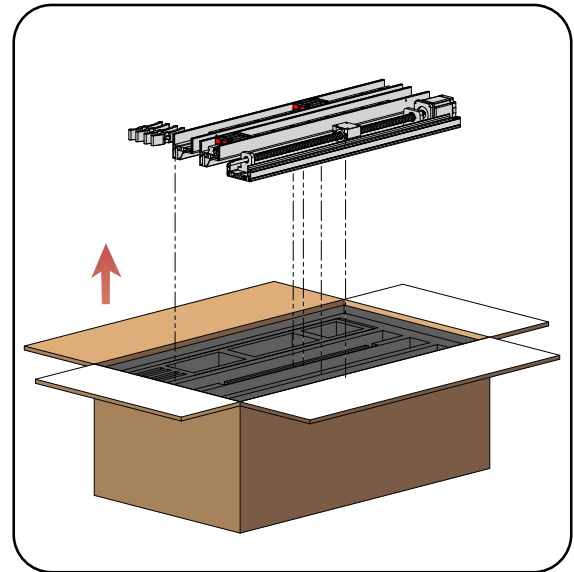
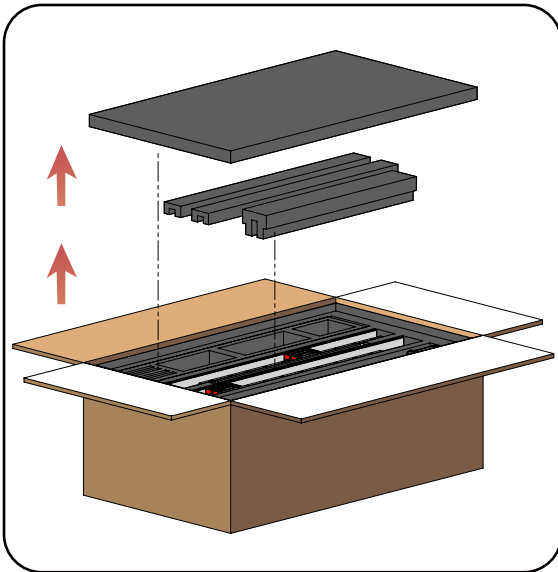

Remove the left protective profile, right protective profile, pearl cotton, and density boards on both sides.

Remove the second layer of pearl cotton.

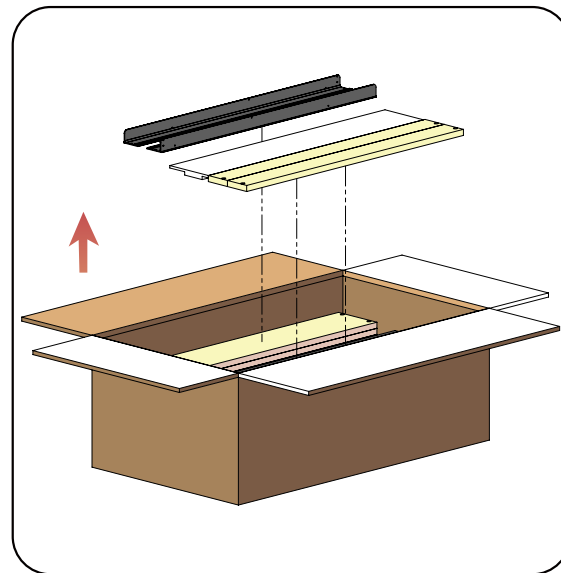
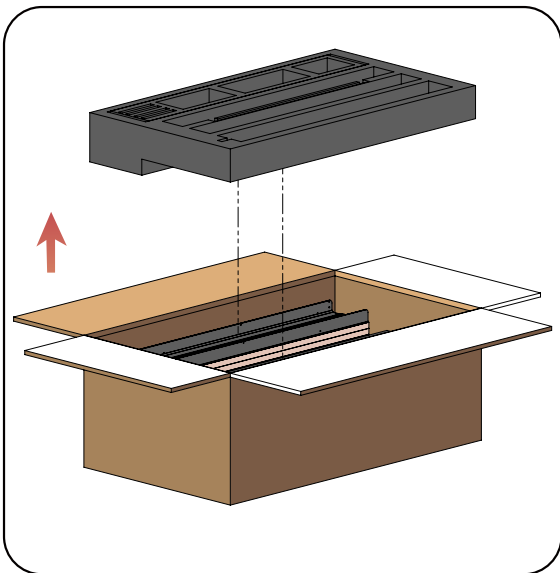

Remove the middle density board, density board support.

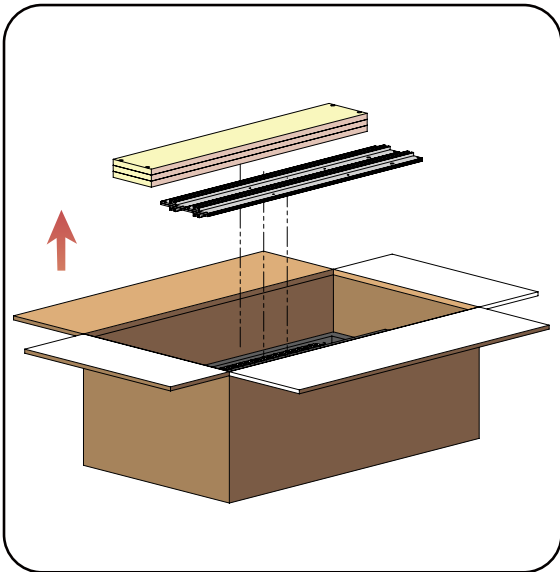

Remove the pearl cotton.

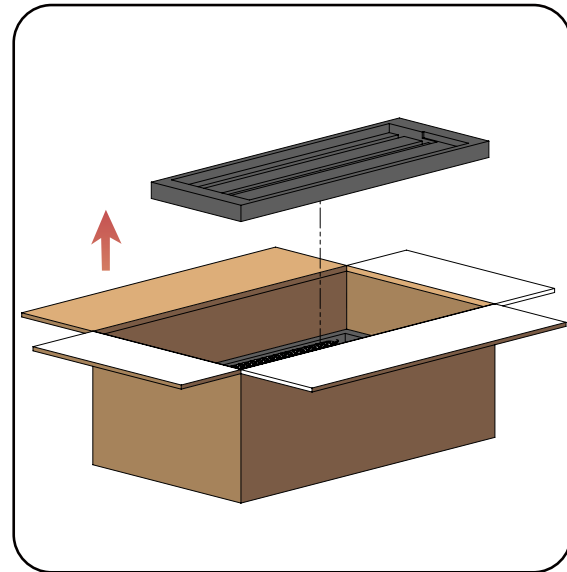

Remove the drag chain, 500W spindle, X-axis motor assembly, spindle motor mounting seat, acrylic guard, trimming machine mounting seat, control box assembly, power cord, safety goggles.

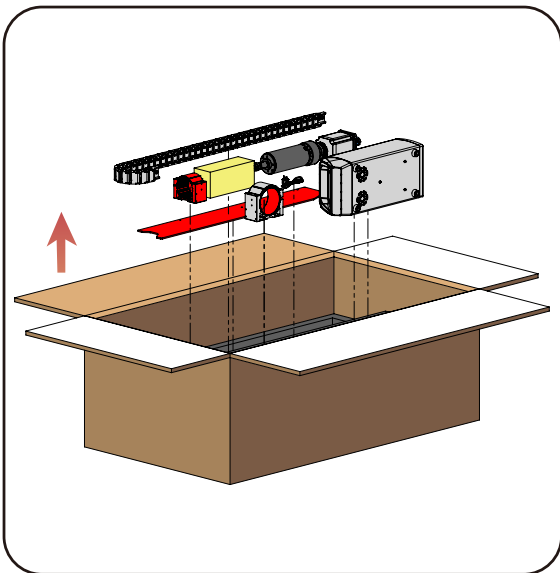

Remove the pearl cotton.

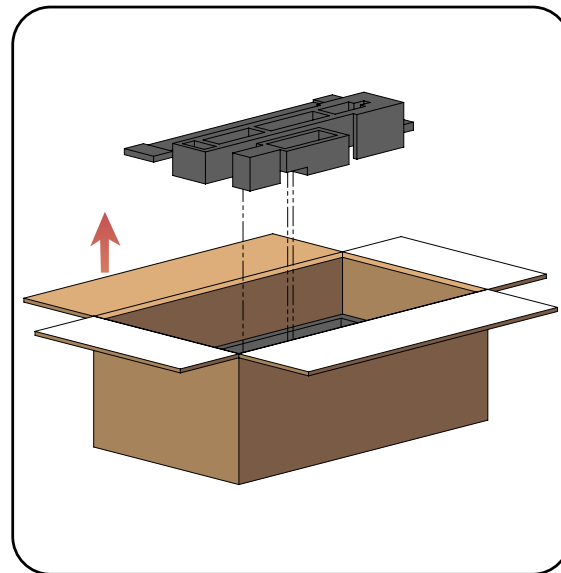

Remove the Z-axis components, X-axis components, rear base panel, front base panel.

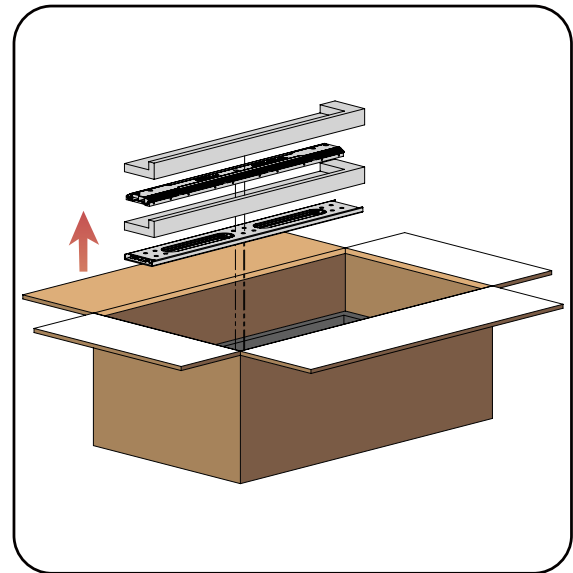
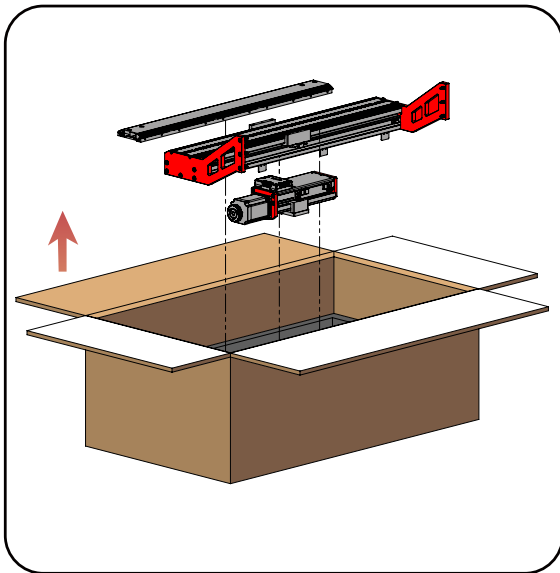

2.Part list

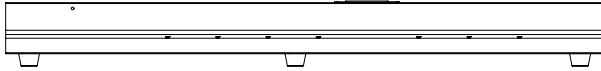

Left Component *1

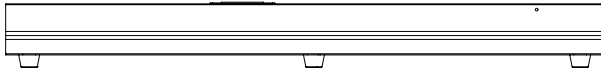

Right Component *1



Two Side Density Boards *2



Middle Density Boards *3

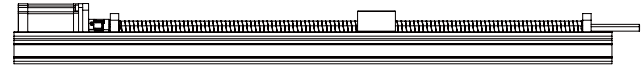

Y-axis Support Component *1

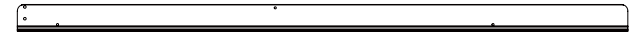

Right Protective Profile *1



Left Protective Profile *1

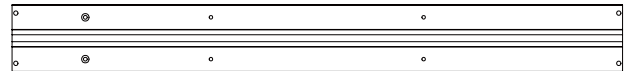

Density Board Support *4

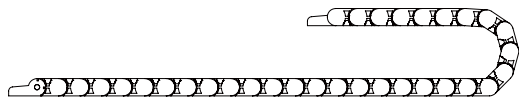

Drag Chain *1

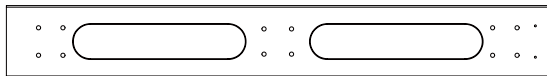

Y-axis Drive Connection Beam *1

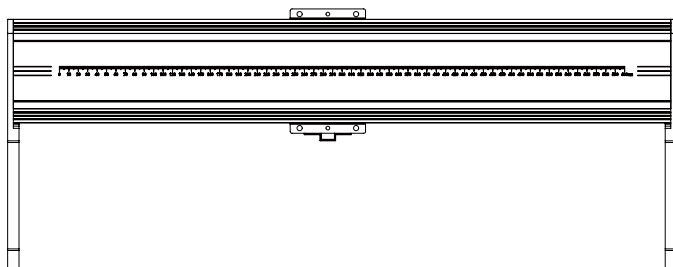

X-axis Component *1

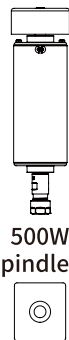

500W Spindle *1

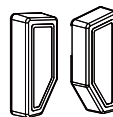

Infrared beam *1

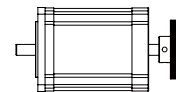

X-axis Motor Assembly *1

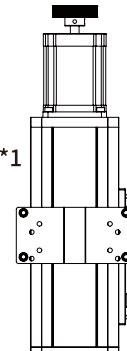

Z-axis Component *1



Magnetic Block *1

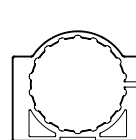

Spindle Mounting Seat *1

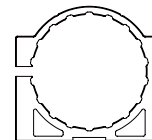

Trimming Machine Mounting Seat *1

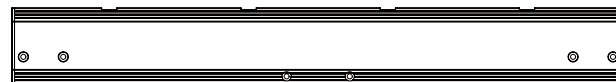

Rear Base Panel *1

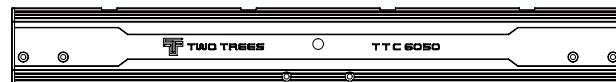

Front Base Panel *1

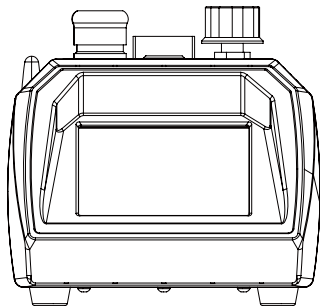

Control Box *1



Acrylic Guard *2



Machine M4X3 screw*2

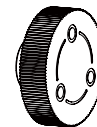

Motor Hand-wheel *1



Round head M5X12 screw*4

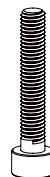

Cup Head M5X30 Screws *4



Cup Head M5X12 Screws *16



Cup head M5X15 screw*12



Cup Head M5X65 Screws *4



Cup Head M5X55 Screws *4

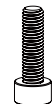

Cup Head M5X18 Screws *6



Cup Head M5X20 Screws *28



Cup Head M4X5 Screws *2



Countersunk head M4X8 screw*8



Cup Head M4X10 Screws *1

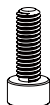

Cup Head M4X12 Screws *4



Cup Head M3X5 Screws *14



Round head M3X6 screw*8



M8 screw*4



Self-tapping M3X10 screws *4

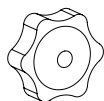

M8 Hand screw the nut*4



CNC workholding plate*4

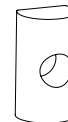

Pressure plate rotating shaft*4

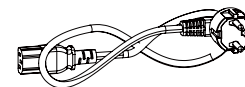

power cable*1

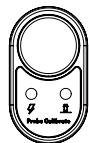

Tool setting apparatus*1

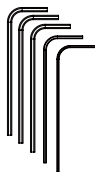

Hexagonal wrench*5



crosshead screwdriver*1

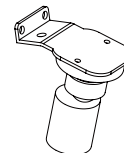

spotlight*1

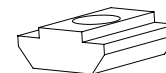

M8 slider nuts *4

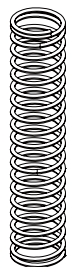

spring*4



cutter*10

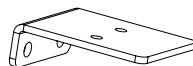

Tow chain bracket*3

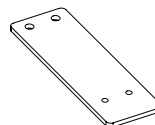

Towing chain mounting plate*1



Open wrench *2



M4 slider nuts *1



M8 gasket*8



data cable*1



cable tie*15



φ5X8Locating pin*8



TF Card*1

3. Machine Assembly

3.1 Base Assembly

3.1.1 Front Beam Installation

Front Base Panel *1

Y-axis Support Component *1

Left Component *1

Right Component *1

Pins *2

Cup Head M5x20 Screws *6

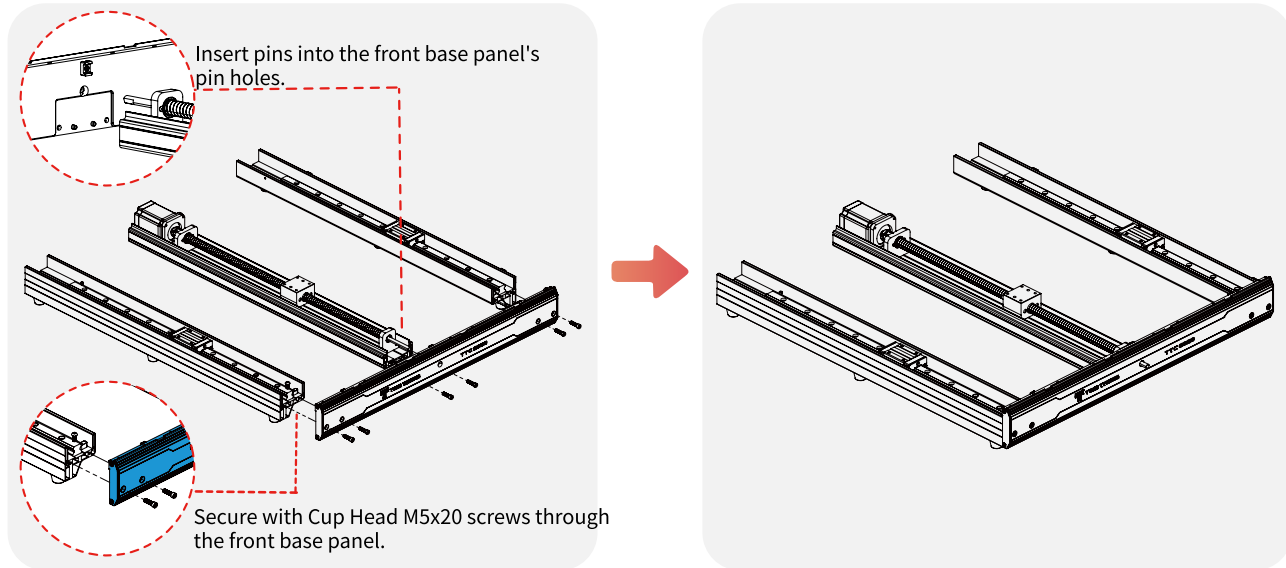

3.1.2 Rear Beam Installation

Rear Base Panel *1

Pin *2

Cup Head M5x20 Screws*6

Cable tie*2

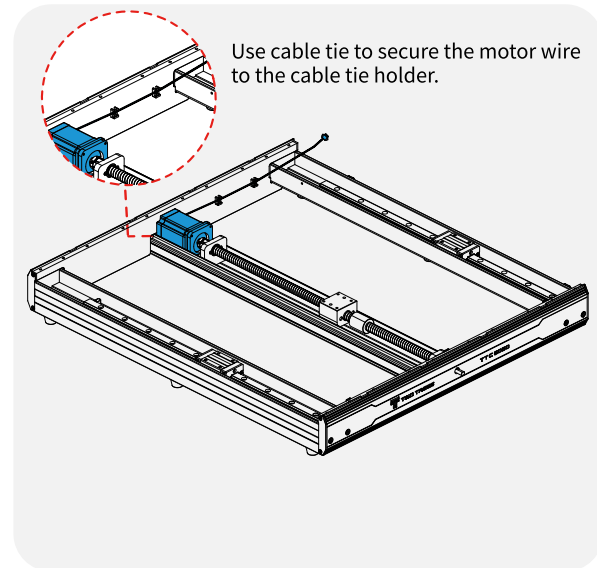
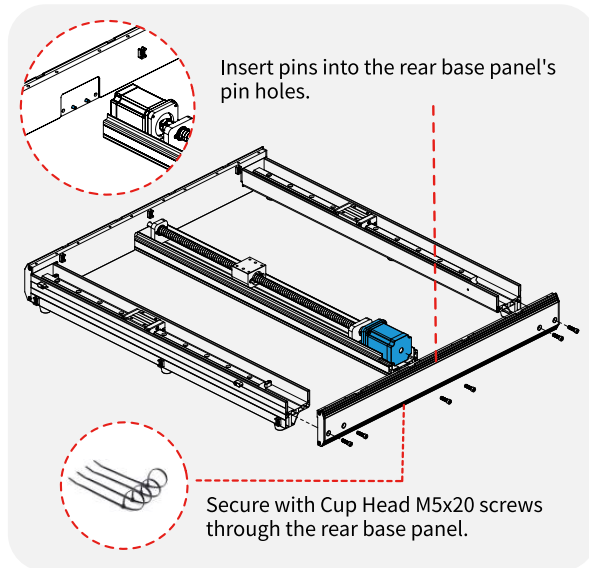

3.1.3Y-axis Drive Connection Beam Installation

Y-axis Drive Connection Beam *1
Cup Head M5x15 Screws *12

Motor Handwheel *1
Machine M4x3 screw*2

Pins *2

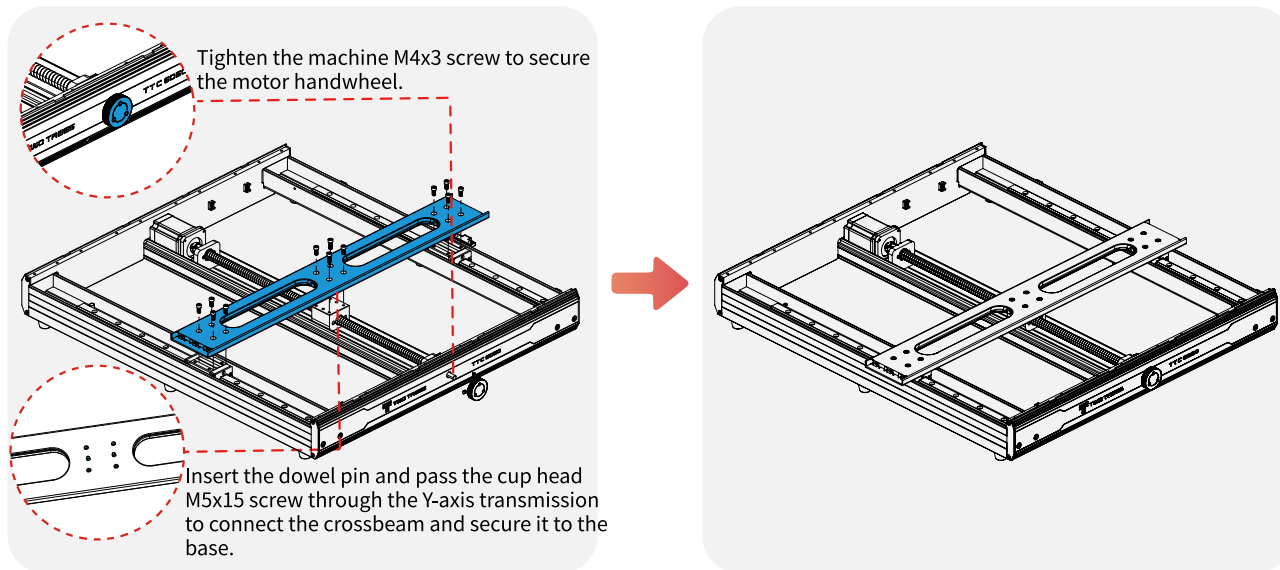

3.1.4 Protective Profile Installation

Left Protective Profile *1
Right Protective Profile *1
Round head M5x12 screw*4

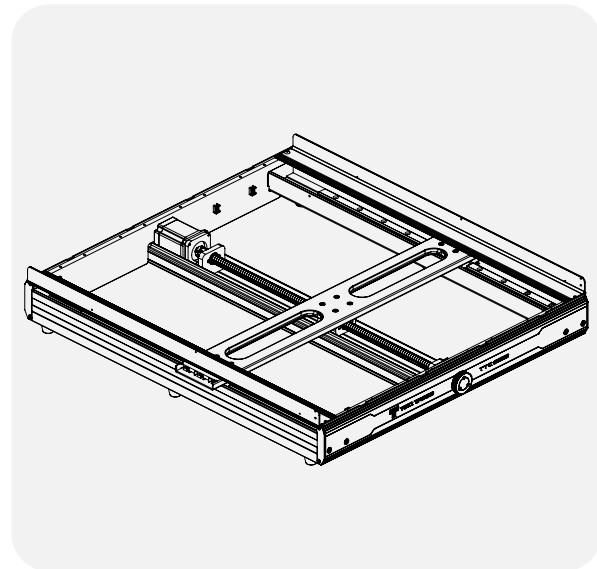
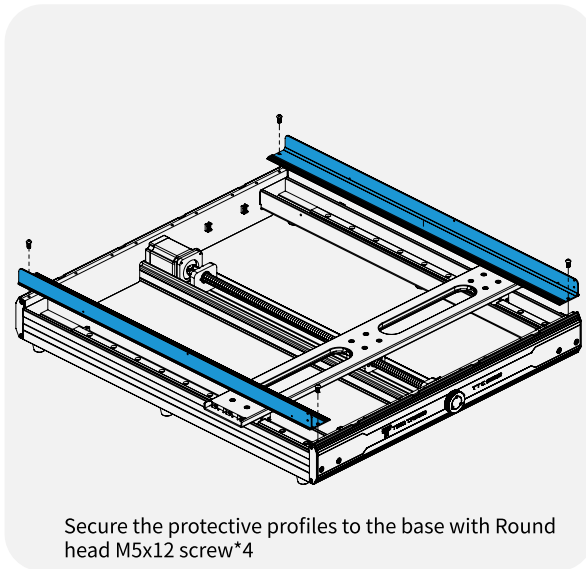

3.1.5 Laser Infrared Alarm Installation

Infrared beam*1 Cable tie* 3
Self-tapping M3x10 screws *4

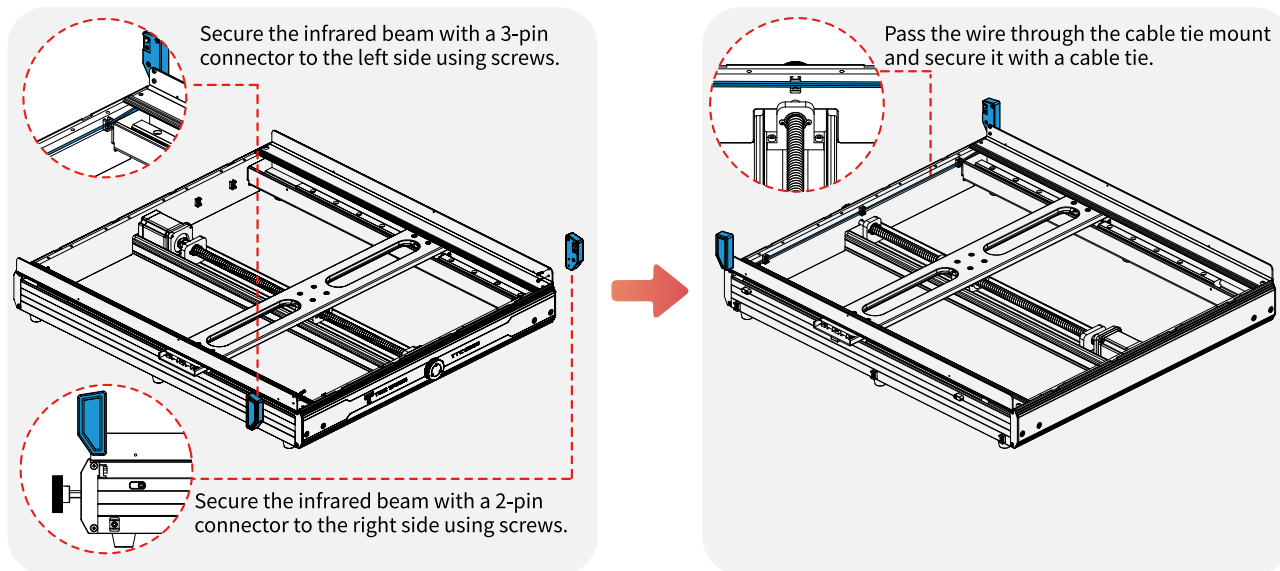

3.1.6 Bottom Sheet Metal Bracket Installation

Bottom Sheet Metal Bracket *1
Cup Head M4x5 Screws *2

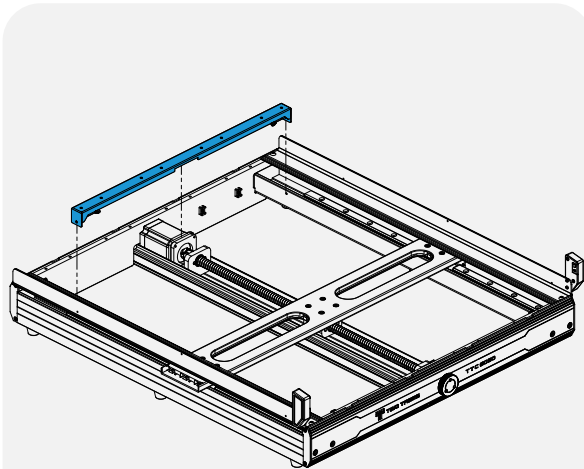

Secure the bottom sheet metal bracket to the base with Cup Head M4x5 screws.

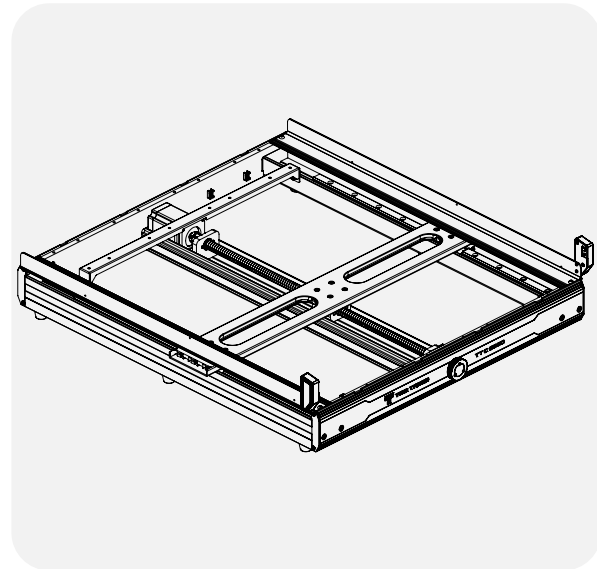

3.1.7 Density Board Support Installation

Density Board Supports *4

Countersunk head M4x8 screw*8

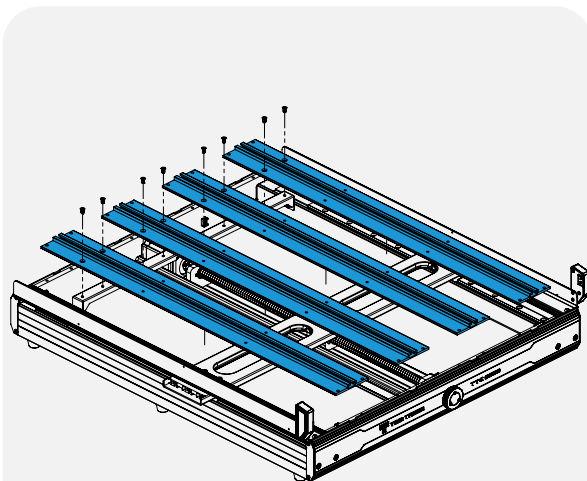

Secure the density board supports to the bottom sheet metal bracket with Countersunk head M4x8 screw

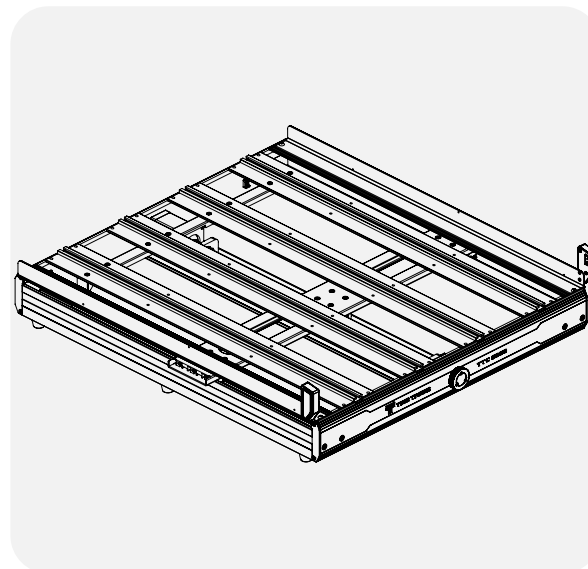

3.1.8 Density Board Installation

Middle Density Boards *3

Side Density Boards *2

Cup Head M5x12 Screw *16 Cup Head M5x20 Screw *16

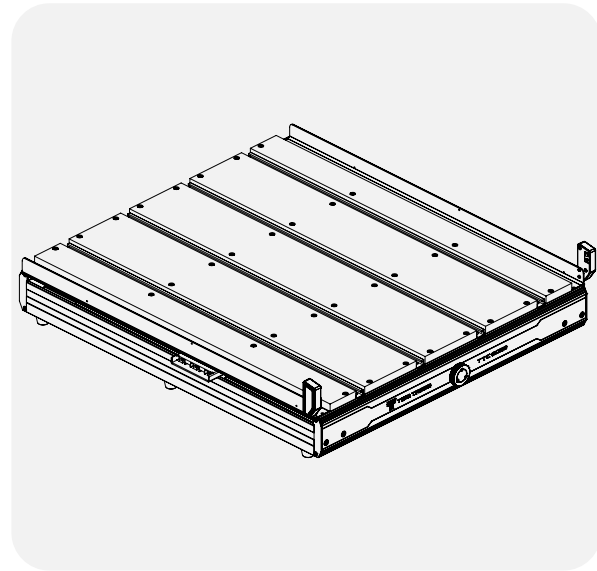
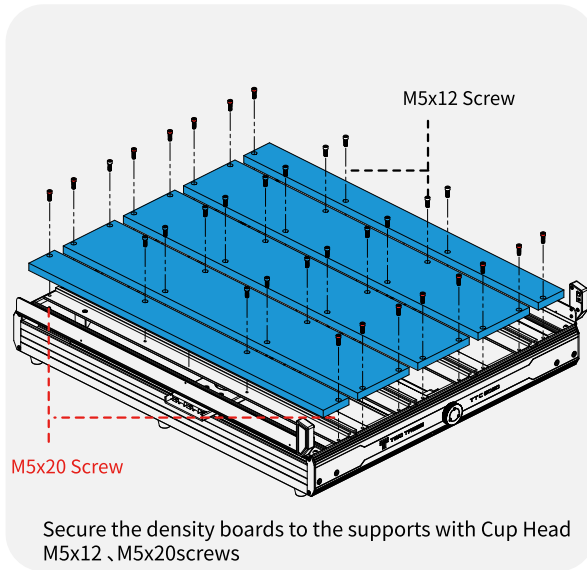

3.2 X-axis Assembly

3.2.1 Handwheel Motor Component Installation

X-axis Component *1

X-axis Motor Assembly *1

Cup Head M4x12 Screw *4

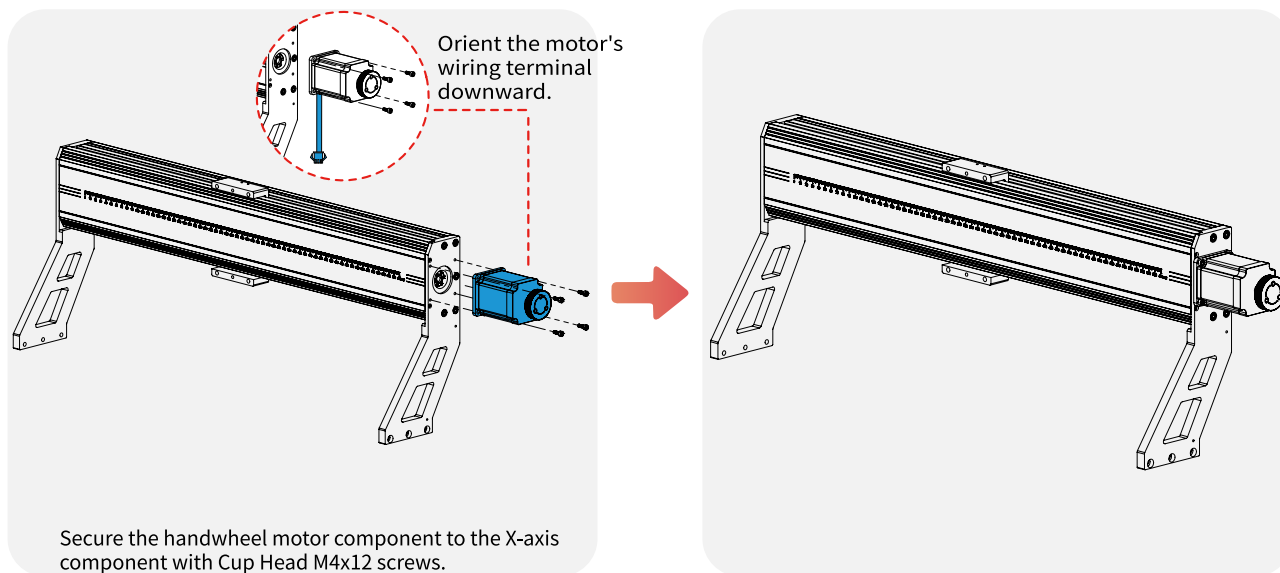

3.3 Main Assembly

3.3.1 X-axis Assembly Installation

Cup Head M5x18 Screws *6

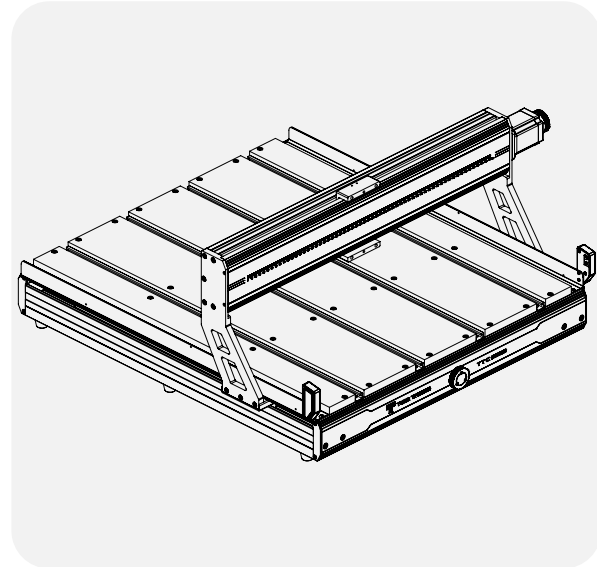
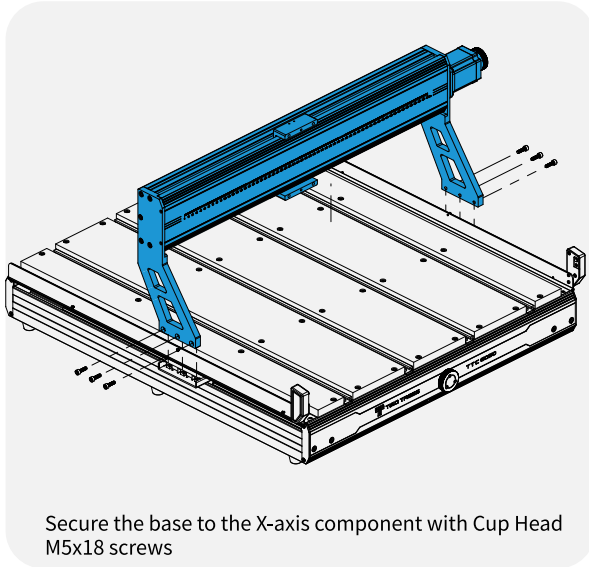

3.3.2 Drag Chain Support Plate Installation

Tow chain bracket*3

Towing chain mounting plate*1

Cup Head M3X5 Screws *8

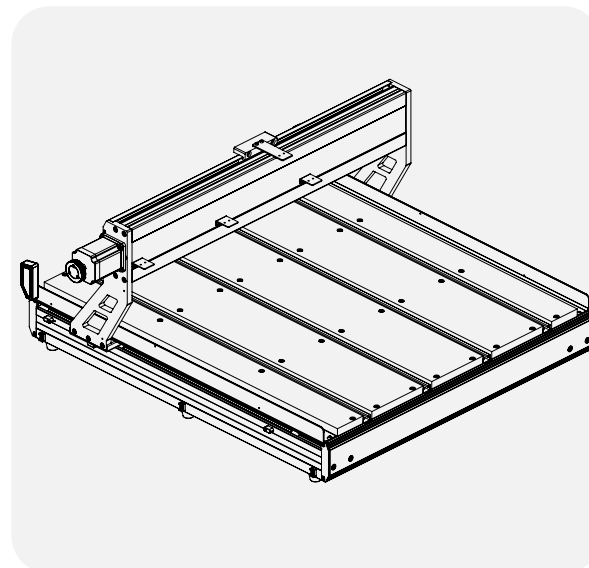
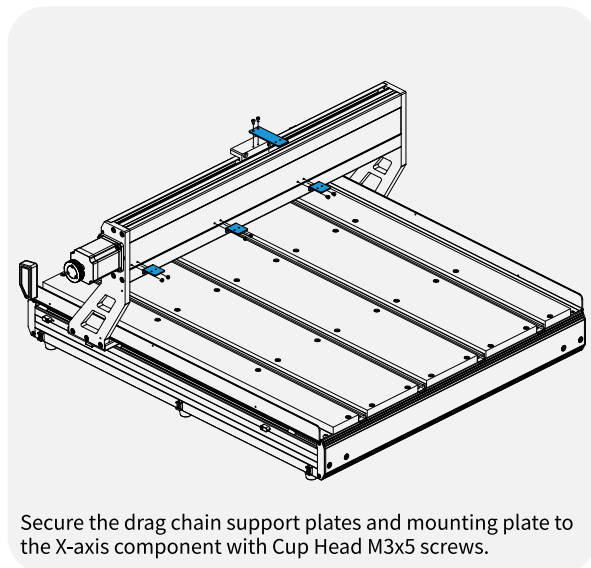

3.3.3 Drag Chain Installation

Drag Chain *1

Cup Head M3X5 Screws *4

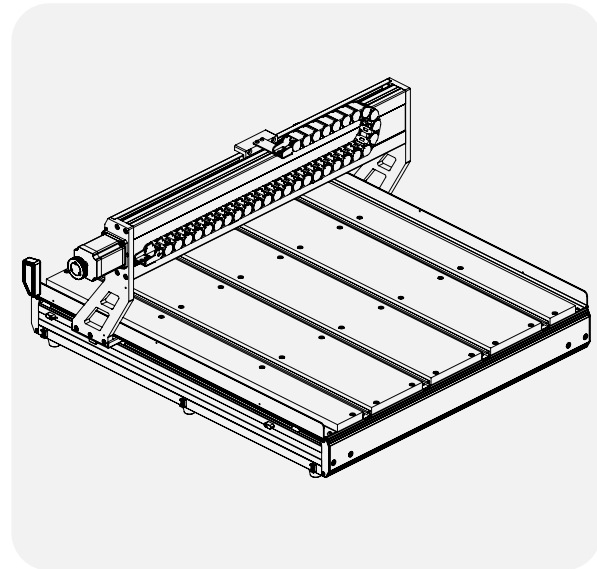
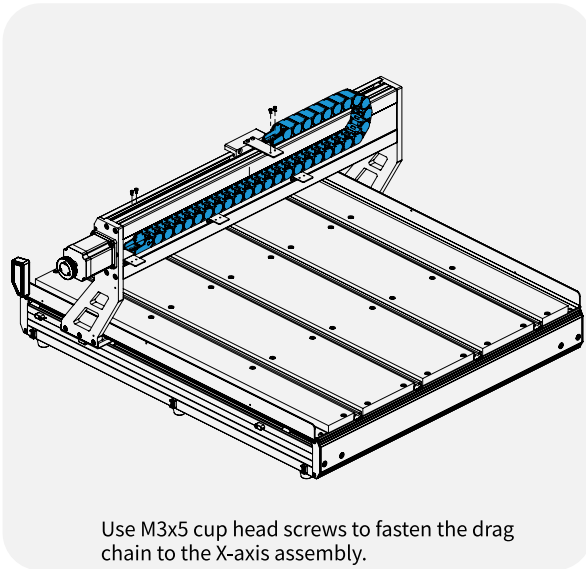

Use M3x5 cup head screws to fasten the drag chain to the X-axis assembly.

3.3.4 Acrylic Guard Installation

Acrylic Guard *2

Round head M3X6 screw*6

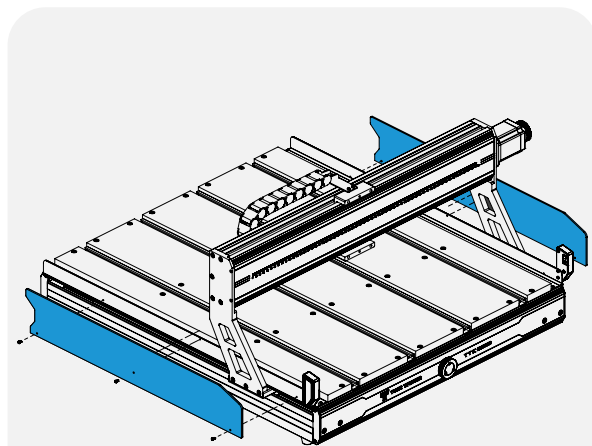

Secure the acrylic guards to both sides of the machine with Round head M3x6 screws.

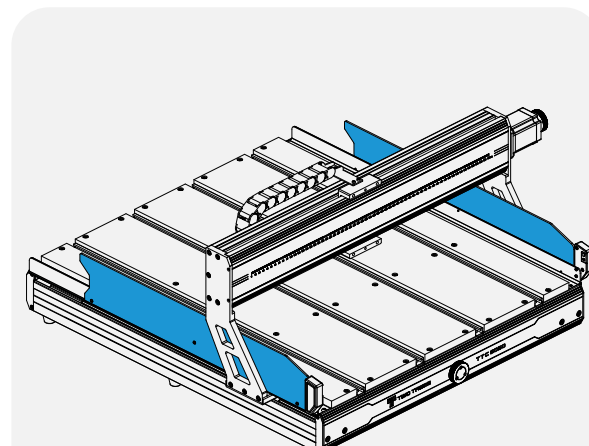

3.4 Z-axis Assembly

3.4.1 Z-axis Component Installation

Z-axis Component *1

Cup Head M5X30 Screws *4

Pins *2

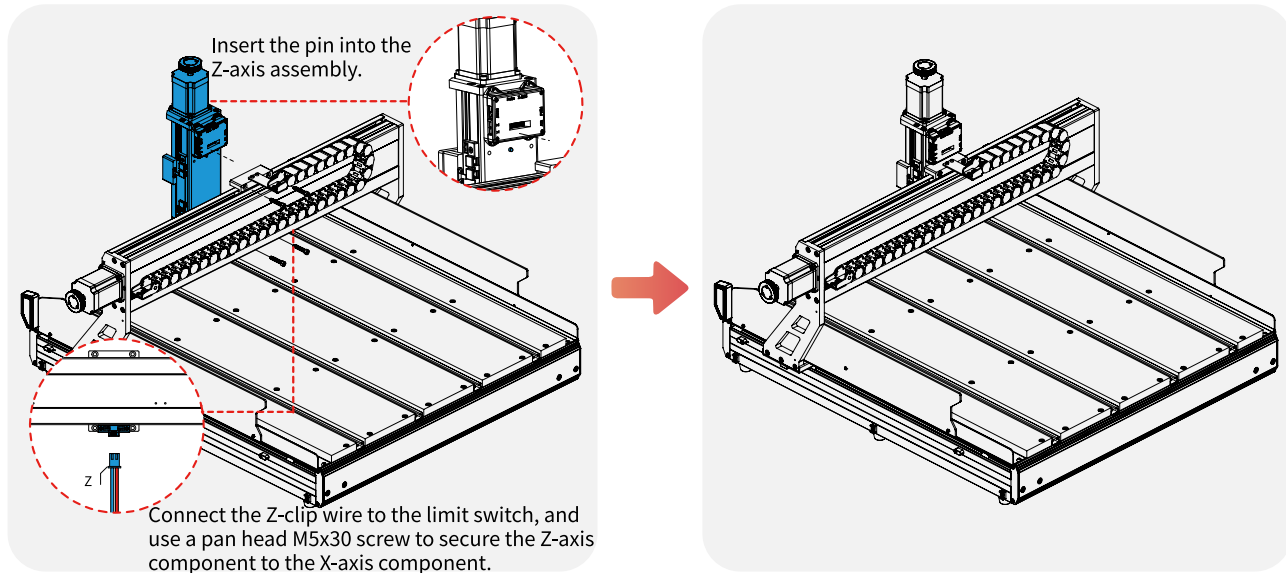

3.4.2 Spindle Installation

Spindle Mounting Seat *1

Spindle Motor *1

Cup Head M5x55 Screw *4

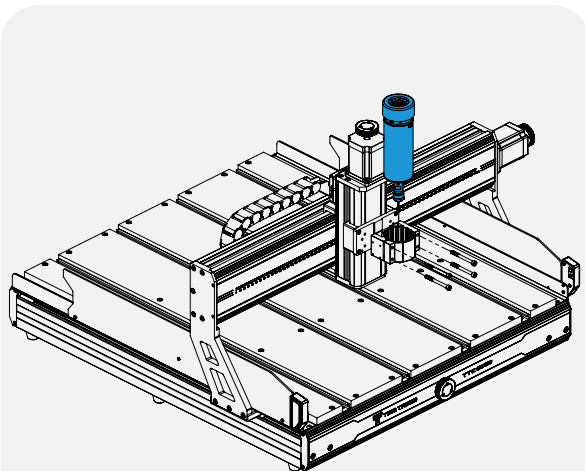

Secure the spindle motor in the center position with cup head M5x55 screws through the spindle mounting seat and lock it to the Z-axis component.

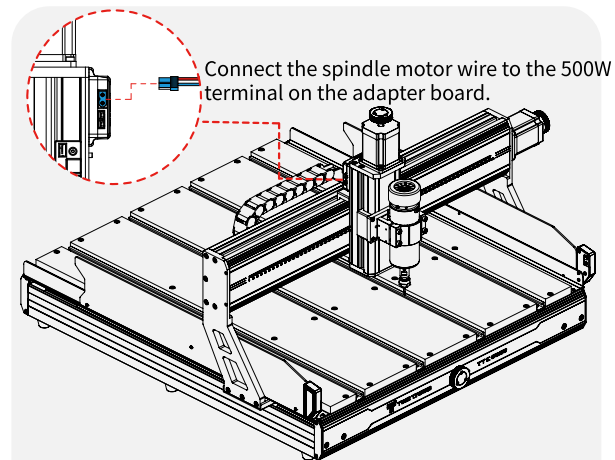

3.4.3 Lighting Installation

spotlight*1

Cup Head M3x5 Screw *2

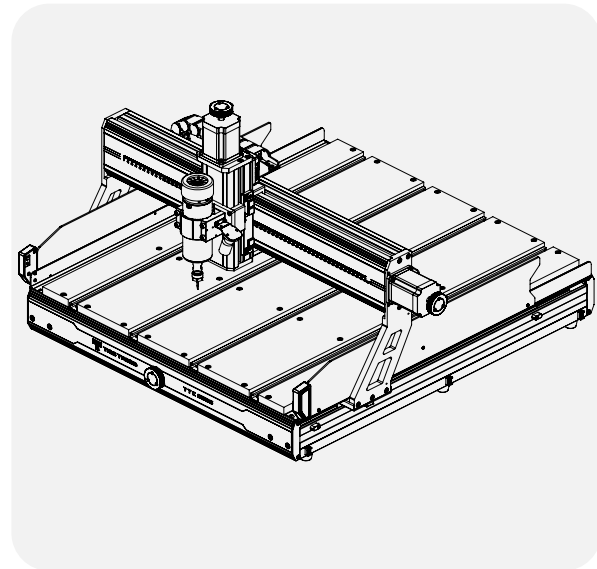
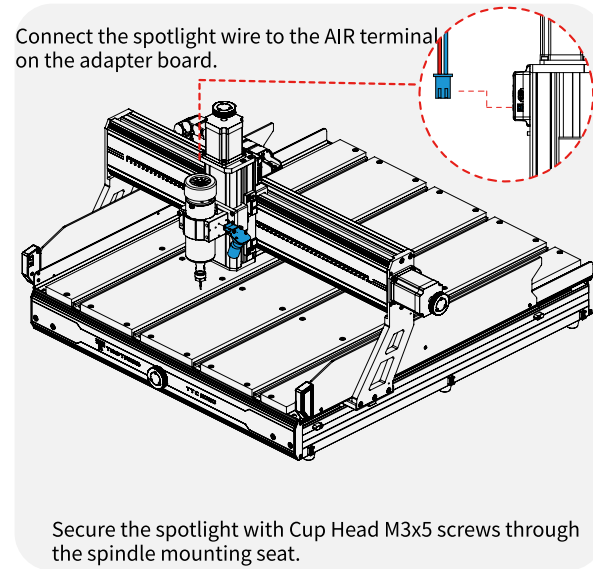

3.5 Machine wiring

3.5.1 Control Box Wiring

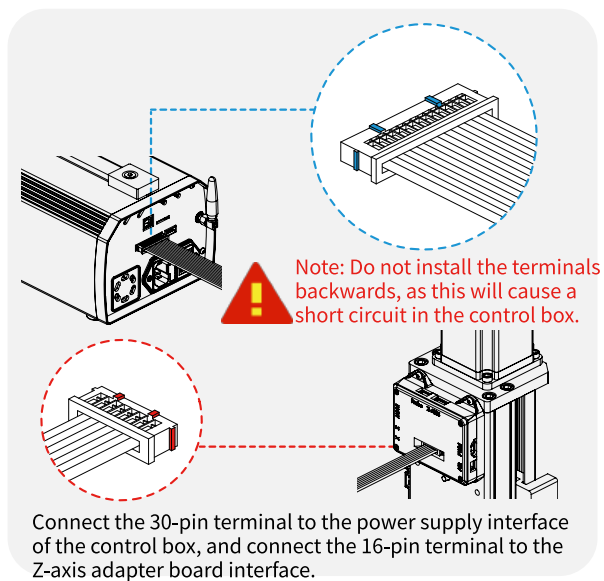

3.5.2 Infrared Beam Connection

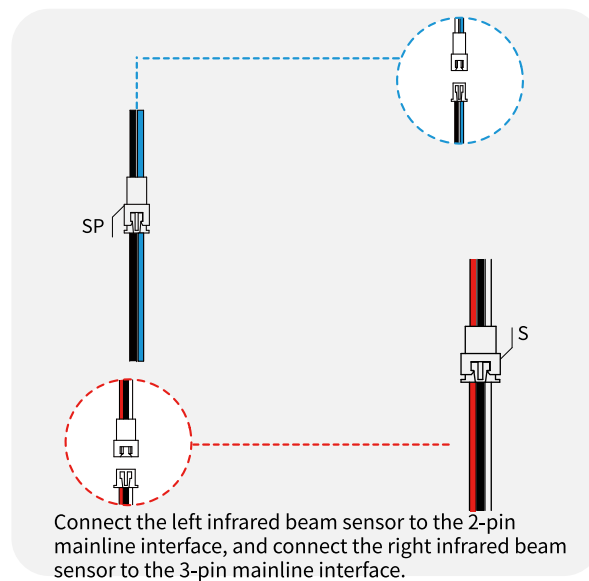

3.5.3 Wiring for X and Y Motors

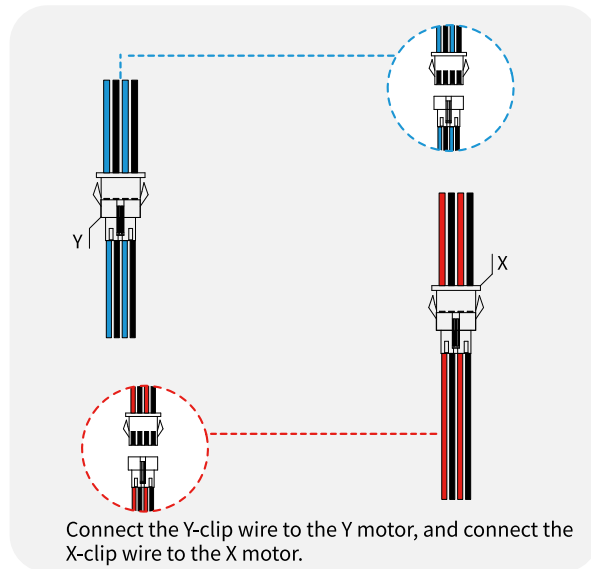

3.5.4 Wiring for the Y limit switch

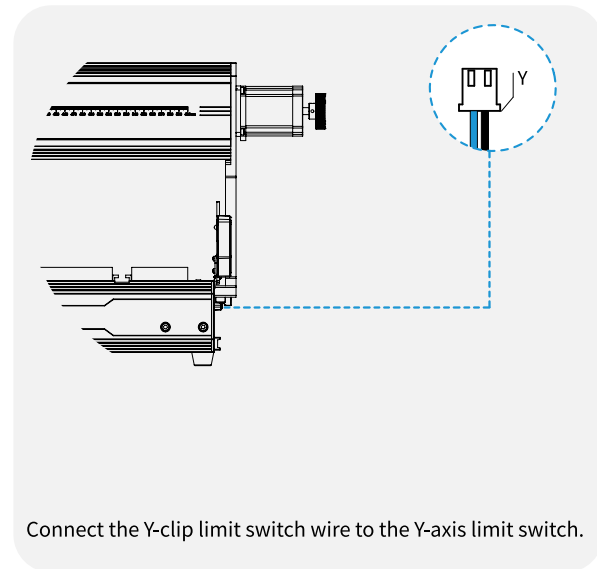



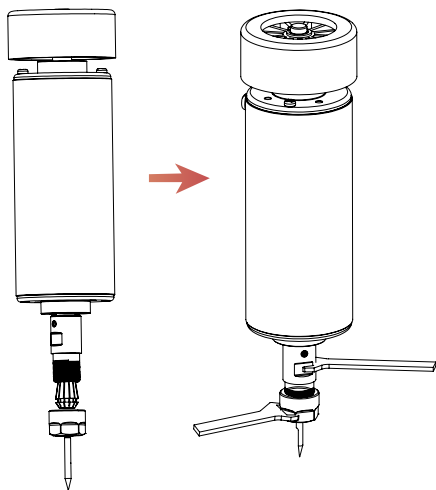

4. Operating Instructions

Step 1: Tool Installation

Note: The clamping length of the tool should be about 1/2 or 1/3 of the total length of the tool.



	Cutting length	Ovreal length	count Flute	Explanatory note
 V-Bit 0.393 Inch(10mm) 90-degree	11mm	50mm	2	V-Bit tools are generally used for engraving V-style letters. They could also be used to remove the background and leave areas flat on the fac of the material.
 Straight Cut 0.125 inches (3.175mm)	20mm	38mm	2	Straight cut can be used for Roughing, Area Clearance, Cutouts, Inlays and Profiling
 MillCutter 0.125 inches (3.175mm)	12mm	39mm	2	Designed for routing where upward chip removal, tool rigidity, long life and high quality finish is desired.
 30 degree carving cutter 0.125 Inch (3.175MM diameter, 0.1 end)	15mm	27mm	1	Use for fine detail engraving

Step 2: Fixture Installation

Secure the workpiece by adjusting the butterfly nut. (The parts used here: M8 Hand screw the nut, CNC workholding plate, Pressure plate rotating shaft, M8 screw, spring, M8 gasket, M8 slider nuts)

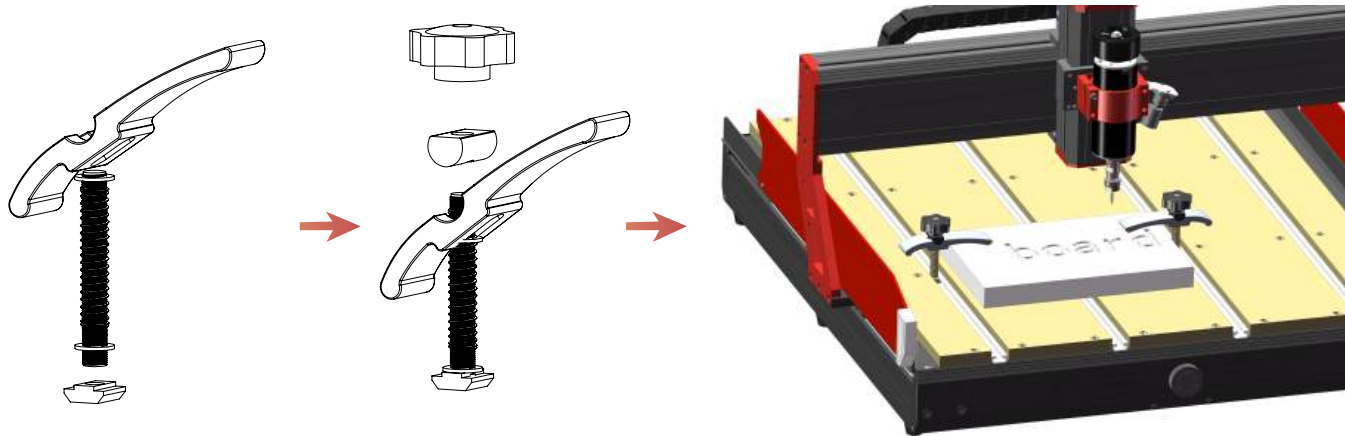

Step 3: Wire Connection

Secure the workpiece by adjusting the butterfly nut.

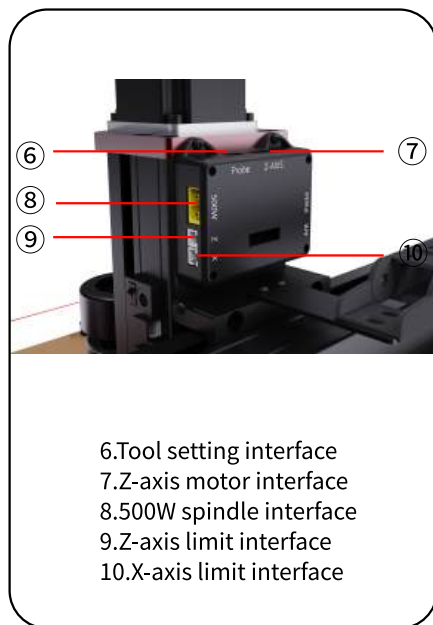
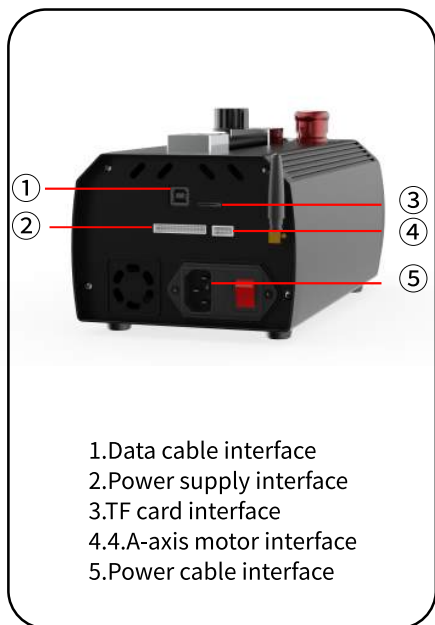

Step 4: Power On

Operate the machine through the screen.

Save the NC file to a TF card.



Plug the power cord into the control box, turn on the power



click settings

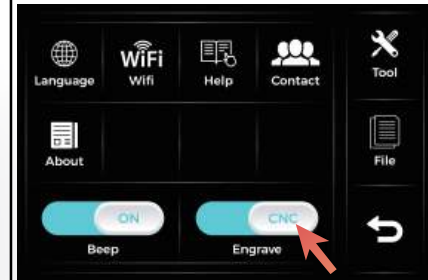

switch to CNC mode

Step 5: Familiarize with the Operation Interface

operate the machine through the screen

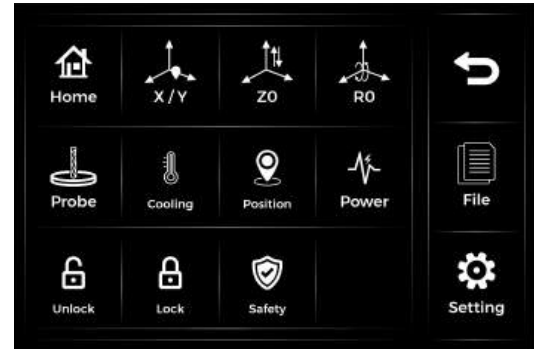
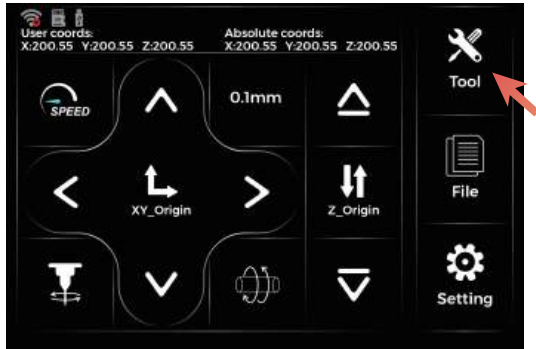

Switching Z-axis and rotary



Speed regulation



Click Tool



Spindle or Laser switch

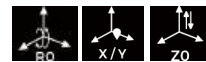

Back to the original point of customisation



Infrared Beam



Unlock/lock Motor



Turn on the air pump



Setting the tool origin



Adjustment of spindle or laser working power



Back to the machine tool origin



Setting tool coordinates

Step 6 : Set the coordinate origin

Setting the origin of coordinates

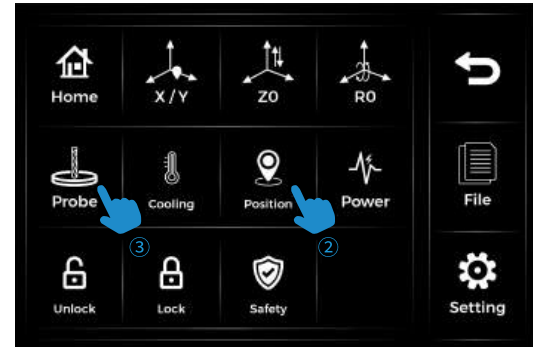
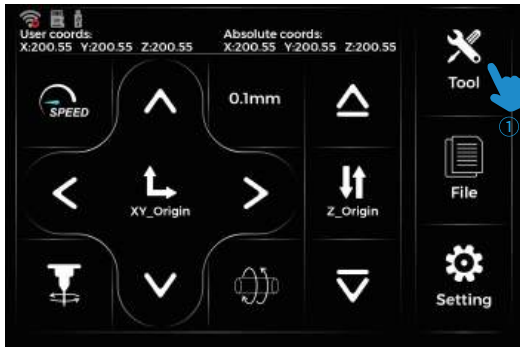

Connect the tool setter and place it directly below the Z-axis over the material. Tighten the tool in the tool setter's chuck. Click "Position," then click "Probe." When the blue light turns on and the screen displays "Tool Setting Successful," the tool setting is complete.



Connecting the probe to the back of the Z-axis

Note: Only one click is required to position

The user coordinates after successful probe will show
X: 0 Y: 0 Z: 24.5



After each use, the tool setter can be fixed on one side of the machine using a magnetic block.

Step 7 : Select File Engraving

Select the file and start engraving.

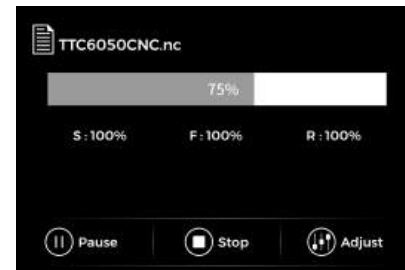
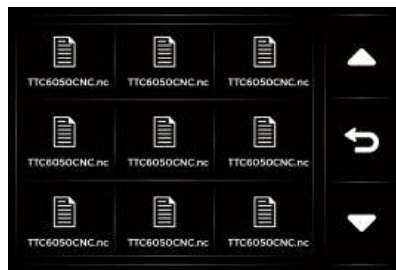
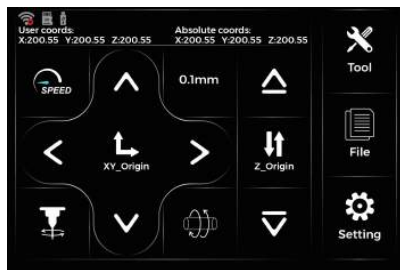

Note: Set appropriate feed rates based on the hardness of the material and tool.

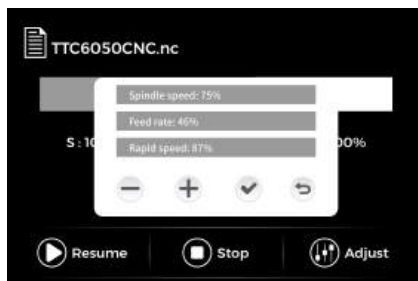

Option to start or stop the program



Click Adjustment button you can change the rate and speed



Suspension and continuation



End of carving

5.Common Questions and Answers

1.Q&A Motherboard

Q1: Motor or limit switch not working.

A1: Please confirm that the motherboard wiring is correct, as shown in the figure-1, in the case of correct installation, ensure that the wiring is not loose.

2. Q&A of Power supply

Q1: No response after power-on.

A1: Pls check if cable is loose and plug it again.

A2: Check if there is voltage at the power socket interface, and if there is current at the power input. If the former does not have the latter, it is a problem with the power supply.

A3: Check if the power socket is loose and the power indicator is on. Please check if the power indicator of the chassis is on. If the light is on but the machine is not working properly, check whether the indicator light on the motherboard is on. If it is not lit, the output power cable is loose, or the motherboard has a problem.



Figure-1



Figure-2

3.0&A of Screen

Q1:When the screen does not show

A1:As shown in the figure -2. Pls check if the screen cable is loose and re-tighten,Or change the line sequence restart.

A2: The screen line is loose: There will be a vibration during the transportation of the machine. The vibration may cause the wire plug inside the machine to loosen and cause poor contact or no contact, At this time the screen of the machine will turn white and not work properly. Pls check if the line has problems firstly.

A3: Motherboard or screen problem: If there is no problem with the screen line, then there is a problem with the motherboard or the screen. If there are multiple machines, you can replace the "bad" with a normally displayed screen. If the good screen can be displayed normally, it is a problem with the original screen, if not, there is a problem with the motherboard. If you encounter this problem, you can contact the after-sales customer service.

4.Q&A of Motor

Q1: If the motor has a jitter fault, or there is no response after plugging in the power.

A1: First check whether the motor wire and the motor terminal or the motherboard port are firmly connected if there is looseness or poor contact, and the power can be tested after re-plugging.

A2: Exchange the positions of the motors . If there is no response after re- plugging, the problematic motor and the normal motor can be exchanged at the motherboard port for testing. After the test, the motor fault is judged. (A. Motorline Problem B. Drive problem C. Motor problem).

A3: Motor line problem: After confirming that the motor is ok, please exchange positions of the problematic line on the main board and the motor with the motor line that has no problem, and then test it. If there is no problem, then it is the problem of the motor line. If it still doesn't work, pls check the driver.

A4: Note: Adjust the motor wiring on the main board. As shown in the figure -4, if it is Y-axis jitter, you can exchange the bad motor line and the good motor line (Y/XZ/E-axis motor line are ok) ports. At the same time, it is necessary to match the motor line to the corresponding motor. After power-on, test it by testing the function of the moving shaft.

A5: Drive problem: Under the premise of confirming that the motor and the motor line are no problem, check the motor drive again. There may be a problem with the drive and a new drive needs to be replaced.

5.Q&A of Motherboard

Q1: Motherboard does not read card.

A1: TF card problem: How to determine if there is any problem with the TF card, first check whether the card can be used normally on the computer. If the TF card can be used normally on the computer, first save the file to the computer and format the card at the same time. After the card is put on the machine and tested, if it is not recognized after the power-on test, it proves that the TF card has a problem and needs to be replaced.

A2: Check if the card slot is loose. Long-term use of the card slot may cause the card holder to shake, resulting in poor card reading, and need to replace the new card holder to solve the problem. Sometimes the card may be inserted into the card for a moment and then suddenly no response. You can quickly plug in and out several times and then try to plug in after turning off the power, then take some alcohol to clean it on the card, then insert the card into the card slot, and then insert it several times to see if it can be used normally after cleaning.

A3: TF card chip oxidation, you can try to apply a little alcohol on the sD card, and then insert the card into the card slot, insert a few more times, see if it can be used normally after cleaning.

6.Q&A of Software Tutorial.

Q1: Where can I find the engraving software tutorial?

A1: The homepage contains a letter to customers with the Wikipedia URL and QR code for this product. Visit the relevant URL to learn about the engraving programming software.

6.Product Parameter

Model: TTC6050	Laser/CNC function switch: Supported
Color: Red and black	Speed control: Supported
Main material: Aluminum + plastic parts + C7 ball screw + linear guide rail	Tool setting control: Supported
Compatible engraving materials: Plywood/ MDF/Solid wood board/Acrylic/Carbon fiber/ Aluminum/Copper/Stainless steel	Spindle motor: Standard 500-watt spindle
Machine weight: 35.9KG	Supported systems: MacOS\Windows\Linux
Working range: 600mm X 500mm X 100mm	Total power consumption: 150W
Touch screen: 3.5-inch resistive touch screen (480*320 resolution)	Motion structure type: XYZ